



VB0194

MODELS ERV140 ECM*, HRV160 ECM* AND HRV160

**READ AND SAVE THESE INSTRUCTIONS
INSTALLER: LEAVE THIS MANUAL WITH HOMEOWNER**

Register your product online at: www.broan.com/register



*These products earned the ENERGY STAR® by meeting strict energy efficiency guidelines set by Natural Resources Canada and the US EPA. They meet ENERGY STAR requirements only when used in Canada.



7 72371 12789 0

22643 rev. 02

Congratulations!

You have made an excellent choice! The operating principle of your Heat Recovery Ventilator or your Energy Recovery Ventilator will give you personal comfort you have never known before.

We have prepared this User Guide especially for you. Please read it carefully to ensure you obtain full benefit from your unit. Over the coming months, you will increasingly appreciate the feeling of living in a more comfortable house.

Please take note that this manual uses the following symbols to emphasize particular information:

⚠ WARNING

Identifies an instruction which, if not followed, might cause serious personal injuries including possibility of death.

CAUTION

Identifies an instruction which, if not followed, may severely damage the unit and/or its components.

NOTE: Indicates supplementary information needed to fully complete an instruction.

We welcome any suggestions you may have concerning this guide and/or the unit, or ways to better serve you. Please forward all correspondence at the address below:

Broan-NuTone LLC
Indoor Air Quality Mkt.
926 W. State St.,
Hartford, WI 53027

CAUTION

Make sure at all times that the outside intake and exhaust hoods are free from any snow during the winter season. It is important to check your unit during a big snow storm, so it doesn't draw in any snow. If this is the case, please operate the unit in recirculation mode, or turn it OFF for a few hours. Do not use your unit during construction or renovation of your house or when sanding drywall. This type of dust may damage your system. Since the electronic control system of the unit is incorporated with a microprocessor, it may not operate correctly because of external noise or very short power failure. If this happens, unplug the unit and wait approximately 10 seconds. Then, plug the unit in again.

TABLE OF CONTENTS

1. DEFROSTING MODE	4
2. CONTROLS	4-5
2.1 BOOTING SEQUENCES	4
2.2 INTEGRATED CONTROL	5
2.3 OPTIONAL MAIN AND AUXILIARY CONTROLS	5
3. MAINTENANCE	6-7
3.1 QUARTERLY MAINTENANCE	6
3.2 ANNUAL MAINTENANCE	6-7
4. TROUBLESHOOTING	8-10

REPLACEMENT PARTS AND REPAIR

In order to ensure your ventilation unit remains in good working condition, you must use Broan-NuTone LLC genuine replacement parts only. The Broan-NuTone LLC genuine replacement parts are specially designed for each unit and are manufactured to comply with all the applicable certification standards and maintain a high standard of safety. Any third party replacement part used may cause serious damage and drastically reduce the performance level of your unit, which will result in premature failing. Broan-NuTone LLC also recommends to contact a Broan-NuTone LLC certified service depot for all replacement parts and repairs.

1. DEFROSTING MODE

When the outdoor temperature is below 23°F, recovery of heat in HRV units creates frost in the core. For ERV units, when the outdoor temperature is below 14°F, recovery of energy creates frost in the core.

To maintain its proper operation, the unit is programmed to defrost the recovery core. The defrost frequency varies according to the outdoor temperature.

During the defrost cycle, the unit shifts to maximum speed and the dampers close.

After defrosting, the unit returns to the operating mode selected by the user.

2. CONTROLS

2.1 BOOTING SEQUENCES

HRV160 ECM AND ERV 140 ECM UNITS ONLY

The unit booting sequence is similar to a personal computer booting sequence.

Each time the unit is plugged after being unplugged, or a power failure occurs, the unit will perform a 30-second booting sequence before starting to operate.

During the booting sequence, the integrated control LED will light AMBER for 10 seconds. After that, the LED will light RED for the rest of the booting sequence. During this RED light phase, the unit is checking and resetting the motorized damper position.

Once the motorized damper position completely set, the RED light turns off and the booting sequence is done.

NOTE: No command will be taken until the unit is fully booted.

HRV160 UNIT ONLY

The unit booting sequence is similar to a personal computer booting sequence.

Each time the unit is plugged after being unplugged, or a power failure occurs, the unit will perform a 30-second booting sequence before starting to operate.

During the booting sequence, the integrated control LED will light GREEN (unit set in normal defrost) or AMBER (unit set in extended defrost) for 3 seconds, and then will shut off for 2 seconds. After that, the LED will light RED for the rest of the booting sequence.

During this RED light phase, the unit is checking and resetting the motorized damper position. Once the motorized damper position completely set, the RED light turns off and the booting sequence is done.

NOTE: No command will be taken until the unit is fully booted.

2. CONTROLS (CONT'D)

2.2 INTEGRATED CONTROL

All units are equipped with an integrated control, located under the unit, on the recessed side of electrical compartment. Plug the unit. Use the push button (1) to control the unit. The LED (2) will then show on which mode the unit is in.

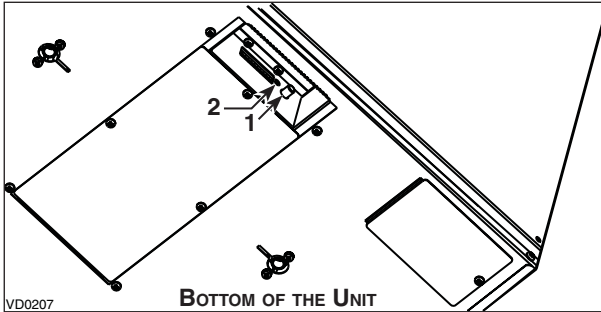

Refer to table below.

LED COLOR	RESULTS
AMBER	UNIT IS ON LOW SPEED
GREEN	UNIT IS ON HIGH SPEED
NO LIGHT	UNIT IS OFF OR CONTROLLED BY A MAIN CONTROL

If a problem occurs during the unit operation, its integrated control LED (2) will blink. The color of the blinking light depends on the type of error detected. Refer to Section 4 Troubleshooting on last page for further details.

NOTE: When using main control, the integrated control must be turned off.

2.3 OPTIONAL MAIN AND AUXILIARY CONTROLS

For more convenience, these units can also be controlled using an optional main control. Only one main control can be connected per unit.

NOTES: 1. The integrated control must be turned OFF to use an optional main control.

2. If an optional auxiliary control is used, its activation will override the main control operation.

For more information about your unit controls, refer to the *Main and auxiliary wall controls user guide* (included with your unit and also available at www.broan.com).

3. MAINTENANCE

⚠ WARNING

Risk of electric shock. Before performing any maintenance or servicing, always disconnect the unit from its power source. When cleaning the unit, it is recommended to wear safety glasses and gloves.

Refer to illustration at right to identify the inner parts of your unit.

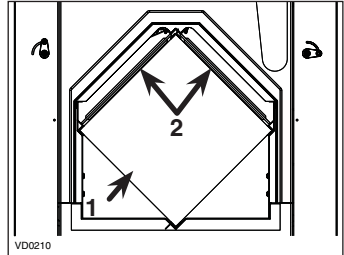

1) ERV or HRV core 2) Core filters

3.1 QUARTERLY MAINTENANCE

1. Turn the unit off and unplug the unit.

2. Remove the unit door by following these steps:

- A** Remove both door lower mechanical screws 8-32 x 1 (1) and set aside.
- B** Open (2) and lift out the door (3).

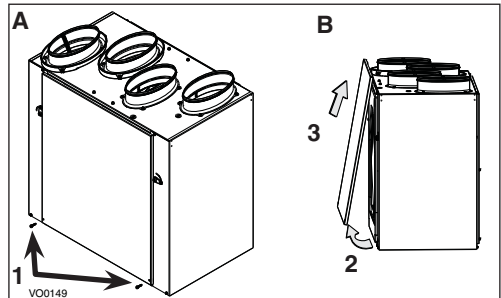

- 3. Slide out both filters from the top of the recovery core.
- 4. Wash both core filters under lukewarm water with mild soap. Rinse thoroughly and let dry completely before reinstalling on the core.
- 5. Slide the cleaned filters into the unit.
- 6. Reinstall the door. Secure it with both mechanical screws 8-32 x 1" previously removed, plug back the unit and turn it on.

NOTE: The mesh side of filters must be on bottom (rests on core surface).

NOTE: The unit will return to its previous setting after a 30-second delay for booting sequence.

3.2 ANNUAL MAINTENANCE

Perform steps 1 and 2 of the Quarterly Maintenance (Section 3.1), then continue with the following steps on next page.

3. MAINTENANCE (CONT'D)

3.2 ANNUAL MAINTENANCE (CONT'D)

3. Slide out both filters (3) and recovery core (4) from the unit.
4. Clean the inside walls of the unit with a damp cloth, then wipe with a clean dry one.
5. Wash both core filters under lukewarm water with mild soap. Rinse thoroughly and let dry completely before reinstalling on the core.

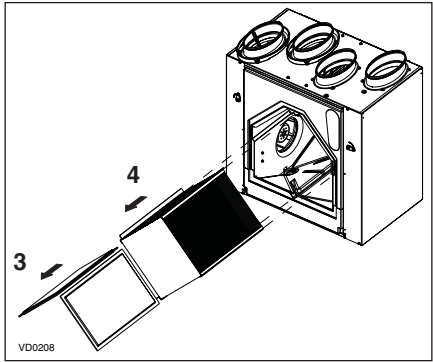

6. Clean the core (refer to table below).

Heat Recovery Core Cleaning	Energy Recovery Core Cleaning
Allow the recovery core to soak for 3 hours in a solution of warm water and mild soap (liquid soap). Rinse lightly, let dry and reinstall.	Remove the dust on the core using a vacuum cleaner and a soft brush attachment.

CAUTION

Do not soak the energy recovery core in water. This core can easily be damaged especially if it is soaked.

7. Slide the cleaned core into the unit.

CAUTION

Make sure to align proper symbol on the core (circle or square) with the one on the unit.

8. Slide the cleaned filters into the unit.
NOTE: The mesh side of filters must be on bottom (rests on core surface).
9. Reinstall the door. Secure it with both mechanical screws 8-32 x 1" previously removed.
10. Clean the exterior hoods, plug back the unit and turn it on.

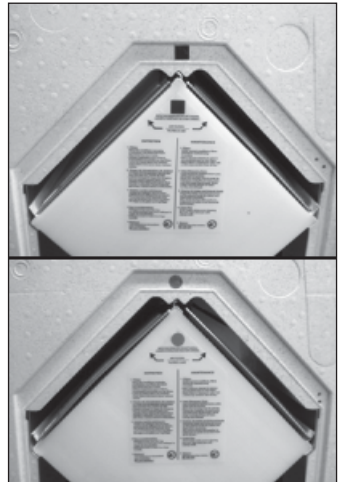

NOTE: The unit will return to its previous setting after a 30-second delay for booting sequence.

4. TROUBLESHOOTING

If the unit does not work properly, reset the unit by unplugging it for one minute and then replug it. If it still not working properly, refer to table below. First make sure that the integrated control is set to OFF (no LED lit).

PROBLEMS		TRY THIS
1.	Nothing works.	<ul style="list-style-type: none"> • See if the unit is plugged in. • See if the unit is receiving power from the house circuit breaker or fuse.
2.	Condensation on windows (air too humid).	<ul style="list-style-type: none"> • Operate the unit on maximum speed ventilation until the situation is corrected. • Leave curtains half-open to allow air circulation. • Store all firewood in a closed room with a dehumidifier or in a well ventilated room, or store the wood outdoors. • Do not adjust the thermostat of your heating system below 64°F.
3.	Inside air too dry.	<ul style="list-style-type: none"> • Temporarily use a humidifier. • Operate the unit in recirculation mode (if available).
4.	Air too cold at the air supply grille.	<ul style="list-style-type: none"> • Check if the exterior hood is not blocked. • Operate the unit in low speed ventilation, in intermittent or in recirculation mode (if available). • Install a duct heater.
5.	The LED of the integrated control is blinking RED.	<p>a) HRV160 ECM and ERV140 ECM only: There is a problem with one of the motors. The unit is OFF. Contact your installer.</p> <p>b) HRV160: There is a problem with the exhaust motor. The unit is OFF. Contact your installer.</p>
6.	The LED of the integrated control is blinking GREEN.	<ul style="list-style-type: none"> • There is a problem with the thermistor. The unit is still working, but will defrost frequently. Contact your installer.
7.	The LED of the integrated control is blinking AMBER.	<ul style="list-style-type: none"> • There is a problem with the motorized damper. The unit is OFF. For a 2½-hour period, the unit will try to reset the damper at every 30 minutes. After 2½ hours, if the problem is not solved, the unit stops trying to reset damper. Contact your installer.
8.	The integrated control push button does not work.	<ul style="list-style-type: none"> • The 30-second boot sequence is not completed. See point 2.1 on page 4.

For wall controls problems, refer to the Troubleshooting section in the *Main and auxiliary wall controls user guide* (included with the ventilation unit and also available at www.broan.com).

If the problem is still not solved, call your installer or the nearest approved Service Center. Also, you can reach the Customer Service Department at the following phone number:
1-877-862-7626.

WARRANTY

This Broan unit is a high quality product, built and packaged with care. Broan warrants to the original purchaser of its product, that such products will be free from defects for the period stated below, from date of original purchase. For all Broan units, the warranty covers parts only against any operational defect. This is a 5-year warranty, except for AE60; this unit having a 2-year warranty. Subject to perform the core maintenance according to user guide recommendations, the heat recovery core (HRV) has a limited lifetime warranty, and the energy recovery core (ERV) has a 5-year warranty, except for ERV200 ECM and ERV250 ECM units; their energy recovery core has a 10-year warranty. If any defect should occur, we urge you to read the user guide carefully. If the problem persists, observe the following rules:

RULES TO FOLLOW

If the unit is defective, contact your ventilation contractor (see address on your user manual cover page). The contractor will determine with you the reason for the defect, and if needed, do the replacement or repair. If ever it is impossible to reach your ventilation contractor, call 1-877-862-7626 (in North America); the personnel will be pleased to give you the phone number of a distributor or a service center near you.

REPLACEMENT PARTS AND REPAIR

In order to ensure your ventilation unit remains in good working condition, you must use Broan genuine replacement parts only. Broan genuine replacement parts are specially designed for each unit and are manufactured to comply with all the applicable certification standards and maintain a high standard of safety. Any third party replacement part used may cause serious damage and drastically reduce the performance level of your unit, which will result in premature failing. Broan also recommends to contact a Broan certified service depot for all replacement parts and repair.

BILL OF PURCHASE

No replacement or repair covered by the warranty will be carried out unless the unit is accompanied by a copy of the original bill of purchase. Please retain your original.

MISCELLANEOUS COSTS

In each case, the labor costs for the removal of a defective part and/or installation of a compliant part will not be covered by Broan.

CONDITIONS AND LIMITATIONS

These units are created for **residential use** only and must be used in a building as defined below:

Building: All structures zoned and/or erected for the act, process or art of human or animal habitation and/or the storage or warehousing of goods.

Residential use: Dwelling, lodging, suite: Building, or part of a building, intended to act as either the domicile to one or several people which can include general sanitary, food consumption and rest facilities. Buildings of only one room or a group of rooms including those occupied by a tenant or owner; comprise the lodgings, the individual rooms of the motels, hotels, rooming/lodging houses, boarding/half-way/foster homes, dormitories, and suites, as well as the stores and the business establishments constituted by only one room in a dwelling.

Commercial use: Agricultural establishment, commercial establishment for assembly, care, or detention: Building or part of a building that does not contain a dwelling, situated on land dedicated to agriculture or farming and used primarily to shelter animals, or for the production, the storage or the treatment of agricultural or horticultural products or animal food. Building or part of a building, used for the display or retail of goods, professional

or personal services, or commodities. Building, or part of a building used by persons gathering for civic activities, religious or political assembly, tourism, educational/vocational training, recreation or the consumption of food or drink. Building, or part of a building used to shelter persons of impaired physical or psychological states, persons requiring palliative care or medical treatments, or persons for reasons out of their control, cannot escape harm or threat of danger autonomously.

Industrial use: Building, or part of a building, used for the assembly, the manufacture, the creation, the treatment, the repair or the storage of products and combustible materials and that contain fuels that when ignited or exploded in sufficient quantity may constitute a risk of fire.

The above warranty applies to all cases where the damage is not a result of poor installation, improper use, mistreatment or negligence, acts of God, or any other circumstances beyond the control of Broan. Furthermore, Broan will not be held responsible for any bodily injury or damage to personal property or real estate, whether caused directly or indirectly by the Broan unit. This warranty supersedes all prior warranties.