

Ventilation Fan with Fluorescent Light

MODEL 769RFT

DESCRIPTION

- Energy-saving Fluorescent Fan-Light Combination utilizes one (1) NEMA Type CFQ13W/G24q 13-watt compact fluorescent lamp (lamp must be purchased separately).
- Electronic Ballast
- White polymeric grille with break resistant polymeric lens.
- Quiet operation with molded one piece blower wheel, and backdraft damper.
- Plug-in motor and light.
- For baths up to 65 sq. ft., other rooms up to 85 sq. ft.
- Refer to NuTone's catalog for a complete listing of accessories to effectively adapt this Fan-Light Combination to your construction requirements.

DESIGN FEATURES

Air Delivery:	70 CFM
Sound Level:	4.0 Sones.
Dimensions:	Housing: 9" x 9" x 5 ³ / ₄ ". Grille: 12 ¹ / ₈ " x 10 ⁷ / ₈ ".
Material & Finish:	Housing: Galvanized steel. Grille: White polymeric.
Motor:	Shaded pole, thermally protected.
Blower Wheel:	One-piece polypropylene, 4 ³ / ₄ " diameter.
Duct Size:	4" diameter.
Electrical Rating:	120 V, 60 Hz, 1.3 A.
Mounting:	Mounting flanges provided.
Ballast:	Electronic.

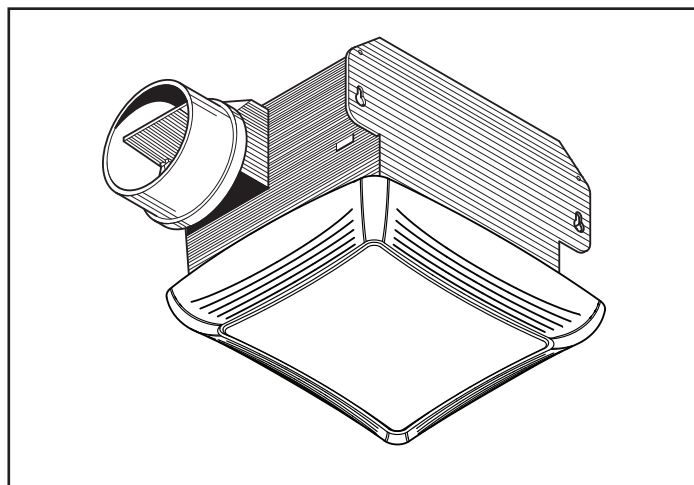

ARCHITECT'S SPECIFICATIONS

Fluorescent Fan-Light Combination shall be NuTone Model Number 769RFT as manufactured by NuTone according to listed specifications. Fan shall ventilate 70 CFM at 0.10 S.P. at a sound level of 4.0 Sones. Housing shall be 9" x 9" x 5³/₄" and connect to 4" duct.

INSTALLATION

- Not for use in kitchens.
- Complete installation instructions are included with each unit.
- Suitable for use over tub or shower when installed in a GFCI protected branch circuit.
- Type IC for use with thermal insulation
- Not for use with solid state speed controls.

Broan-NuTone LLC, 926 West State Street, Hartford, WI 53027 www.Broan-NuTone.com 1-800-558-1711

REFERENCE	QTY.	REMARKS	Project	
			Location	
			Architect	
			Engineer	
			Contractor	
			Submitted by	Date



CERTIFIED TEST DATA

HVI-2100 CERTIFIED RATINGS comply with new testing technologies and procedures prescribed by the Home Ventilating Institute, for off-the-shelf products, as they are available to consumers. Product performance is rated at 0.1 in. static pressure, based on third party testing. Sones are a measure of humanly-perceived loudness, based on laboratory measurements. This NuTone model is listed by Underwriters' Laboratories Inc.

The air delivery of a ventilating system may be determined by:

1. Determine the equivalent duct length for each 90 degree elbow by adding one foot of duct length for each inch of duct diameter, (i.e., a 4-inch diameter duct elbow equals 4 feet equivalent duct length) and an 8-inch diameter duct elbow equals 8 feet equivalent duct length.
2. Add the total straight length of duct and the equivalent length for each elbow to obtain the total equivalent duct length.
3. Locate the intersection of the fan performance curve and the total equivalent duct length curves and draw a vertical line down to the (cfm) scale and read the system air performance. (NOTE: 3/4" x 10" duct equals 6-inch diameter duct.)

California Title 24 compatible electronic ballast.

AIR PERFORMANCE CURVE
(4 In. Duct to 10 Foot Lengths)

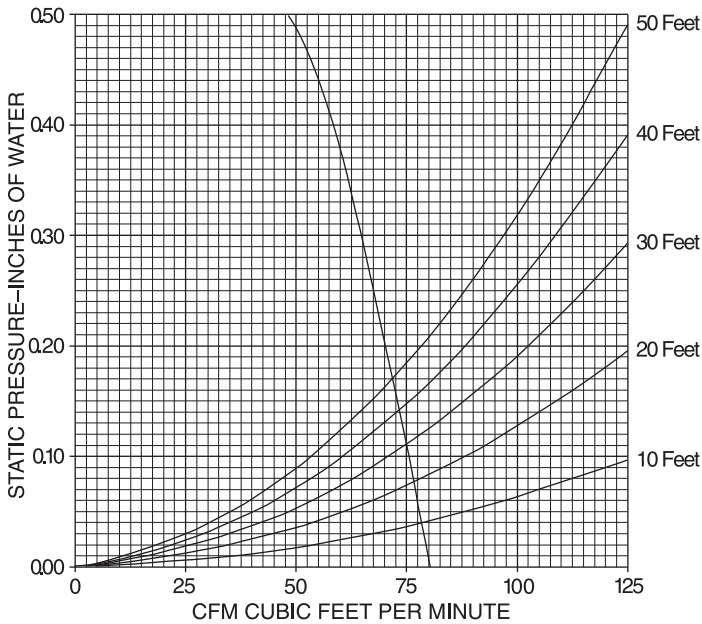

STATIC PRESSURE INCHES OF WATER	0.05	0.1	0.15	0.2	0.25	0.3	0.35	0.4	0.45
CFM	77	75	73	70	68	65	62	58	54

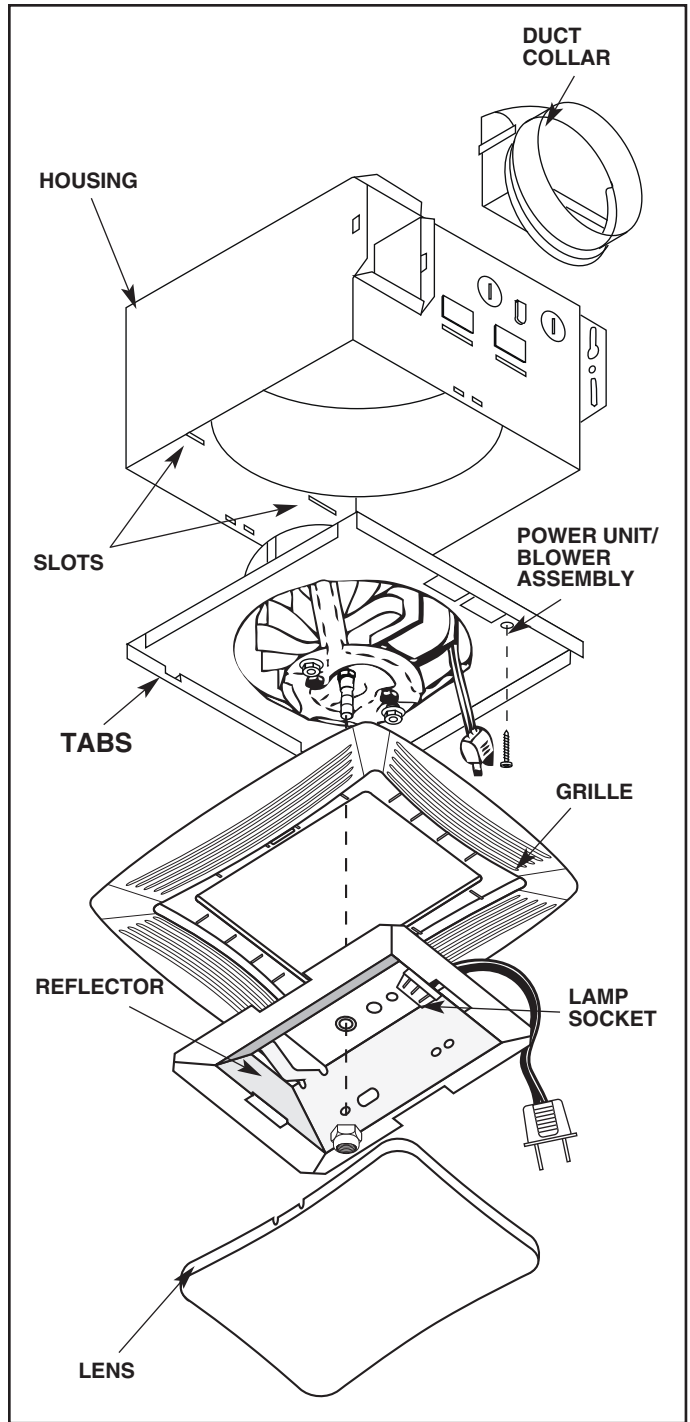

Product specification subject to change without notice.

