



**BROAN® HRV200 ECM**  
**Part no. HRV200TE**  
 50 to 227 CFM (0.4 in. w.g.)



**THE FUTURE OF FRESH AIR**

The whole home ventilation system is a centerpiece of today's energy-efficient homes. Broan introduces its new HE Series that combines the best performance with the best energy efficiency to provide fresher, purer air in your home at a lower overall operating cost. That's Pure Efficiency.

The HRV200 ECM is the perfect solution for mid to large size homes in need for the most energy-efficient ventilation solution.

- Up to 227 CFM at 0.4 in. w.g.
- High efficiency heat recovery core with a sensible recovery efficiency of 81% at 32°F and 70% at -13°F
- ECM\* motors
- Minimal power consumption of 19 W and 3.4 CFM/Watt at 64 CFM
- Merv 6 grade filters and optional HEPA filtration
- Electronic balancing and no balancing dampers

• Included wall mounting bracket  
 \*Electronically Commutated Motor.

**REPAIRS AND MAINTENANCE**

The HRV200 ECM high output ECM motors are permanently lubricated. The electronic circuit board eliminates electromechanical parts, reducing repair time to a minimum.

**WARRANTY**

The HRV200 ECM is protected by a 5-year warranty on parts only, except for the heat recovery core, which is covered by a limited lifetime warranty, with the original proof of purchase.

Available at:



**HEAT RECOVERY VENTILATOR**

**Controls**

The exclusive VT9W main wall control, sold separately, is the only compatible wall control to be used with the HRV200 ECM.

At installation, use the VT9W main control to perform electronic balancing, without balancing dampers!

Optional auxiliary controls also available; for more details, refer to the User Guide - Main and auxiliary wall controls available at [www.broan-nutone.com](http://www.broan-nutone.com).

**Option**

HEPA Filter 21996

Additional 0.3 in.w.g. static pressure at highest speed to be considered. Refer to the HEPA filter instructions for more details.

**Defrosting System**

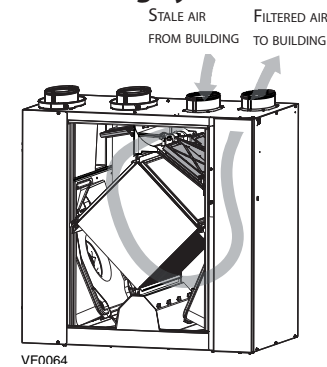

Use the VT9W to choose one of the 3 defrost modes available for recirculation, according to your needs:

- Standard (factory set regular mode)
- Plus (extended defrost for colder areas)
- Discretion (keeps the same speed when performing defrost as performing ventilation)

OUTDOOR TEMPERATURE*		DEFROST IN MINUTES / AIR EXCHANGE IN MINUTES					
		STANDARD		DISCRETION		PLUS	
°C	°F	CONTINUOUS MODE	TURBO FUNCTION	CONTINUOUS MODE	TURBO FUNCTION	CONTINUOUS MODE	TURBO FUNCTION
-27 and less	-17 and less	8/20	8/15	15/20	15/17	12/15	12/12
-20 to -27	-4 to -17	6/28	6/23	12/28	12/23	10/20	10/15
-15 to -20	5 to -4	6/35	6/32	12/35	12/30	8/25	8/20
-10 to -15	14 to 5	6/40	6/35	12/40	12/35	8/30	8/25
-5 to -10	23 to 14	6/50	6/45	12/50	12/45	8/40	8/30
<b>WARMER THAN -5</b>	<b>WARMER THAN 23</b>	<b>NO DEFROST</b>					

\*Outdoor temperature is read by a thermistor located inside the unit, next to fresh air from outside port.

**Requirements and standards**

- Complies with the UL 1812 requirements regulating the installation of Heat Recovery Ventilators
- Complies with the CSA C22.2 no. 113 Standard applicable to ventilators
- Complies with CSA F326 requirements regulating the installation of Heat Recovery Ventilators
- Technical data was obtained from published results of tests relating to CSA C439 Standards
- HVI certified

## DIMENSIONS: HRV200 ECM

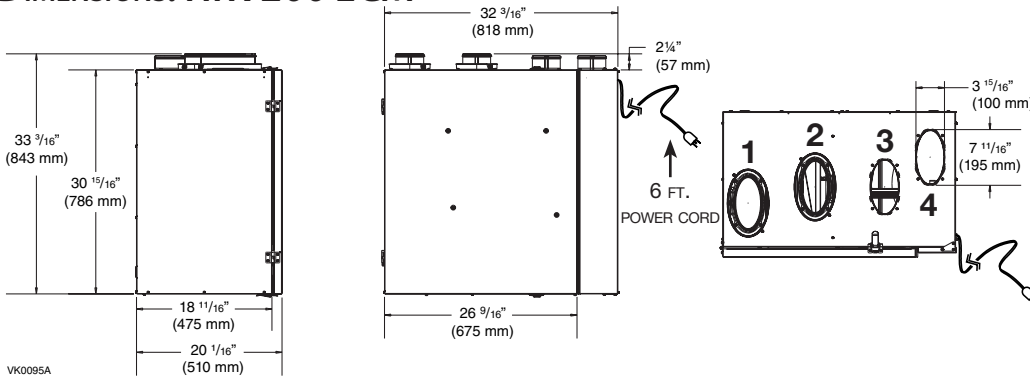

NOTE: ALL UNITS PORTS WERE CREATED TO BE CONNECTED TO DUCTS HAVING A MINIMUM OF 6" DIAMETER, BUT IF NEEDED, THEY CAN BE CONNECTED TO BIGGER SIZED DUCTS BY USING AN APPROPRIATE TRANSITION (E.G.: 6" DIAMETER TO 7" DIAMETER TRANSITION).

- 1: EXHAUST AIR TO OUTSIDE PORT
- 2: FRESH AIR FROM OUTSIDE PORT
- 3: EXHAUST AIR FROM BUILDING PORT
- 4: FRESH AIR TO BUILDING PORT

## VENTILATION PERFORMANCE

EXTERNAL STATIC PRESSURE		NET SUPPLY AIR FLOW			GROSS AIR FLOW					
PA	IN. W.G.	L/S	CFM	M <sup>3</sup> /H	SUPPLY			EXHAUST		
					L/S	CFM	M <sup>3</sup> /H	L/S	CFM	M <sup>3</sup> /H
25	0.1	119	252	430	120	254	433	121	256	437
50	0.2	116	246	416	116	246	418	117	248	421
75	0.3	111	235	401	112	237	403	113	239	406
100	0.4	107	227	384	107	227	387	108	229	389
125	0.5	102	216	369	103	218	369	103	218	372
150	0.6	97	206	352	98	208	352	98	208	353
175	0.7	93	197	335	93	197	335	93	197	336
200	0.8	88	186	318	88	186	318	88	186	318
225	0.9	83	176	301	84	178	301	84	178	301
250	1.0	79	167	284	79	167	284	79	167	282
275	1.1	74	157	267	74	157	267	74	157	267

## FAN CURVE ACCORDING TO SPEED

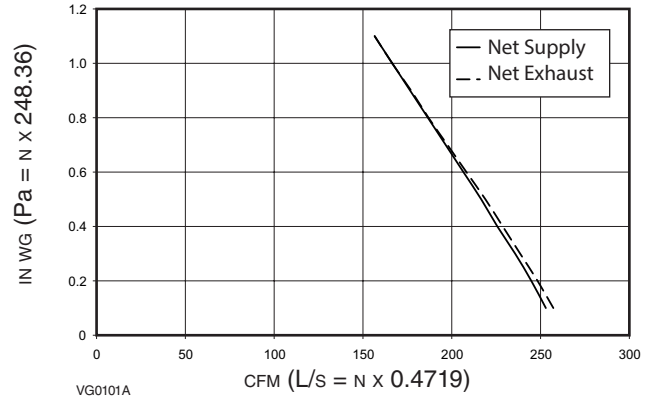

FULLY ADJUSTABLE SPEED RANGE FROM 50 CFM TO MAXIMUM SPEED.

## ENERGY PERFORMANCE

SUPPLY TEMPERATURE		NET AIR FLOW			POWER CONSUMED WATTS	SENSIBLE RECOVERY EFFICIENCY	ADJUSTED SENSIBLE RECOVERY EFFICIENCY	APPARENT SENSIBLE EFFECTIVENESS*	LATENT RECOVERY/MOISTURE TRANSFER
°C	°F	L/S	CFM	M <sup>3</sup> /H					
HEATING									
0	32	30	64	109	19	81	82	84	0
0	32	47	100	170	28	75	77	79	0
0	32	66	140	238	48	70	72	75	0
-25	-13	30	64	109	32	70	71	87	0

\*Data not certified by HVI.

NOTE: All specifications are subject to change without notice.

## SPECIFICATIONS

- Model: HRV200 ECM
- Part Number: HRV200TE
- Total Assembled Weight (including polypropylene core): 94 lb. (43 kg)
- Oval shaped ports; fit 6" round ducts
- Drains: 1/2" (1.2 cm) fittings with 10 ft. (3m) PVC drain
- Core Filters: 2 washable Merv 6 filters
- Housing: Pre-painted steel
- Optional HEPA Filter
- Insulation: Expanded polystyrene
- Mounting: Suspension by chains and springs or wall bracket system
- Supply and Exhaust Blower Motors:
  - Two ECM motors
  - Protection type: Thermally protected
- VT9W wall control offering 5 manual modes: Recirculation, 20 MIN/H, Continuous, Smart and Turbo. VT9W is sold separately.
- Heat Recovery Core:
  - Dimensions: 12" x 12" x 16.6" (30.5 cm x 30.5 cm x 42.2 cm)
  - Exchange surface: 175 ft.<sup>2</sup> (16.3 m<sup>2</sup>)
  - Weight: 12 lb. (5.5 kg)
  - Type: Crossflow
  - Material: Polypropylene
  - Warranty: Limited lifetime
- Unit Electrical Characteristics:
 

Volts	Frequency	Amps	Watts
120	60 Hz	2.2	135

Project:	REMARKS
Location:	
Part no.: HRV200TE	
Qty.:	
Submitted by:	Date:



Broan-NuTone LLC, 926 West State Street, Hartford, Wisconsin, USA 53027 Broan-NuTone.com 800-558-1711



HRV200ECM2210