



InVent™ Humidity Sensing Fans

Modern-styled, high performance fans, with sensing circuitry, that «knows» when to ventilate the room.

- SensAire® Technology detects rapid increases in moisture levels at the ceiling.
- Flexibility for new construction and room-side retrofit from one fan.
- Permanently lubricated motor, engineered for continuous operation.
- 4" round duct connector.
- cUL Listed for use over the bathtubs and showers (when connected to a GFCI protected branch circuit).
- FoldAway™ mounting ears and TrueSeal™ Damper Technology that improves building airtightness.
- ENERGY STAR® qualified.
- Housing Dimension: 7-1/2" x 7-1/4" x 3-5/8" – Fits to 2" x 6" construction.
- Washable, white polymeric Grille: 9-1/4" x 9-3/4".

SPECIFICATIONS

MODEL	VOLTS	AMPS	SONES	CFM	DUCT
AERN110S	120	0,3	1,0	110	4" round

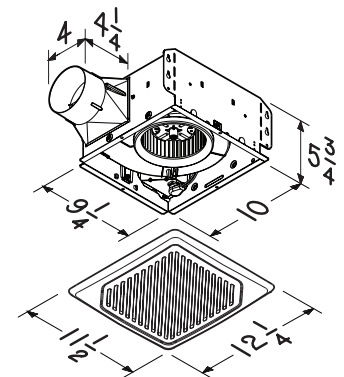

Dimensions shown are in inches.

