

## Technical specifications



POWER UNIT	HHKIT 650A	HHKIT 550E	HHKIT 550A
<b>MAX. SQUARE FOOTAGE OF THE HOME</b>	7,000	4,000	4,000
<b>POWER (AIR WATTS)</b>	650	550	550
<b>FLOORING TYPE</b>	Hard floor or low-pile carpet	Hard floor or medium- to high-pile carpet	Hard floor or low-pile carpet
<b>SOUND LEVEL (DECIBELS)</b>	66 dB	66 dB	66 dB
<b>FILTRATION</b>	Permanent, self-cleaning HEPA filter	Regular	Regular
<b>HYBRID SOLUTION</b>	Yes (bag or bagless)	No (bag only)	No (bag only)
<b>DEBRIS PAIL CAPACITY (L)</b>	22.7	22.7 (bag only)	22.7 (bag only)
<b>DIMENSIONS D X W X H (IN.)</b>	14 5/8 x 13 1/4 x 36 7/8	14 5/8 x 13 1/4 x 29 3/4	14 5/8 x 13 1/4 x 29 3/4
<b>VOLTAGE</b>	120	120	120
<b>CURRENT RATING (AMP)</b>	13.5	12	12
<b>WARRANTY ON PARTS</b>	8 Years	5 Years	5 Years
<b>WARRANTY ON LABOUR</b>	5 Years	3 Years	3 Years
<b>ACCESSORY KIT</b>	Standard	Electric	Standard

**NuTone**  
 CUSTOMER SERVICE  
 1-888-882-7626  
 nutone.ca



### A hybrid solution

Use a large-capacity disposable bag with the HHKIT550A or HHKIT550E. Or choose the HHKIT650A model, which offers bag or bagless option according to your preference.

### Convenient in every way

Large ergonomic latches on the debris pail make emptying your central vacuum child's play. The easy-to-remove debris pail facilitates handling and limits contact with dust.

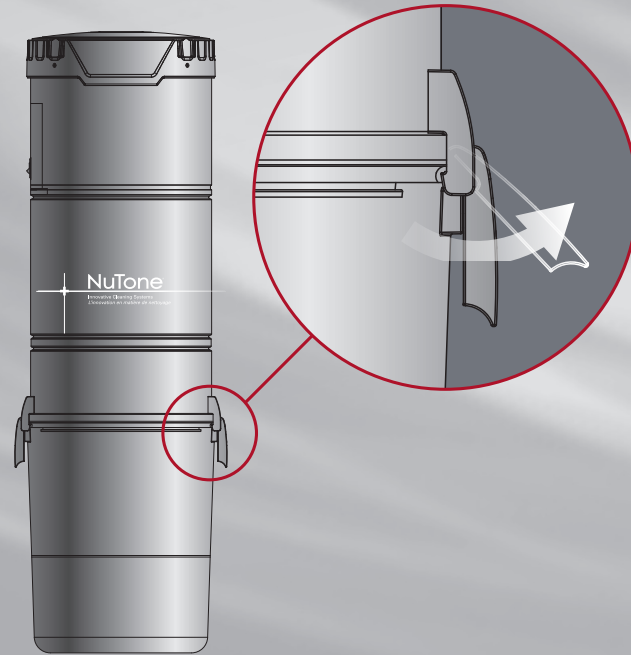

### Hepa filtration

Captures up to 99.97% of all dust and particles\*. Ensures that exhausted air is clean thus may help to reduce symptoms associated with allergies and respiratory problems.

Applicable to model HHKIT650A only.



\*as small as 0.3 micron



### Powerful cleaning

Up to 650 air watts thanks to new Thru-Flow motor. More powerful than the previous product generation. Perfect for homes up to 7,000 sq. ft.



### Designed for quiet operation

Thru-Flow motor allows for quieter overall operation. No muffler required. No air vents required in the power unit.



### Reliable and durable

Proudly designed and manufactured in Canada to high quality and safety standards.

## Optional accessories

### BN165 AIR-DRIVEN BRUSH

- Ideal for homes with a mix of hard floors and carpet. The air-driven turbine cleans low to medium pile carpets effectively and eliminates the need for a separate electric power brush.



### BNHS30 / BNHS35 KNITTED HOSE SOCK

- Protects banisters, walls, furniture, floors, wall coverings and moldings
- Fits all makes and models of hoses
- Available in 30' length (BNHS30) and 35' length (BNHS35)



### V800W CANSWEEP® INLET VALVE

- Makes it easy for debris and dirt to be swept and removed from non-carpeted surfaces
- For use in kitchen, mudroom and bathroom
- Available in white only

### V801W CANSWEEP® TRIM PLATE

- Available in white only

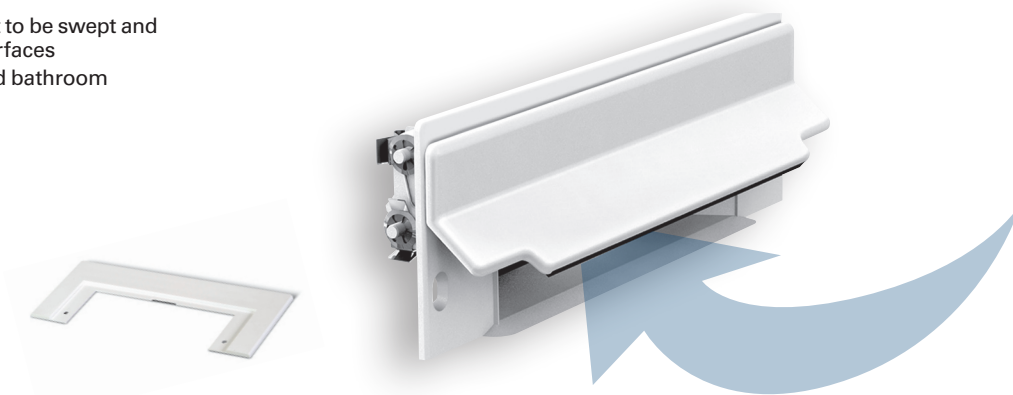

# NuTone

Innovative Cleaning Systems

## The Ultimate Cleaning Experience

CENTRAL VACUUM KITS





# POWERFUL, VERSATILE, AND INCREDIBLY CONVENIENT

NuTone high-performance central vacuum systems make cleaning your home easier in every way. Easy installation, an easy-to-remove debris pail and a permanent self-cleaning filter make cleaning a pleasure. NuTone's hybrid model HHKIT650A gives you the added flexibility of choosing how you use the system: the Cyclonic mode captures debris in the pail, the Bag mode captures all debris in an easy-to-remove disposable bag. The choice is yours!

Affordable, reliable and durable, NuTone central vacuums are manufactured entirely in Canada in accordance with high quality and safety standards. They are designed to guarantee performance and peace of mind for many years to come.

## HHKIT650A Power and Versatility without Compromise

IDEAL FOR HARD FLOORS  
AND CARPETS WITH  
MEDIUM TO HIGH PILE

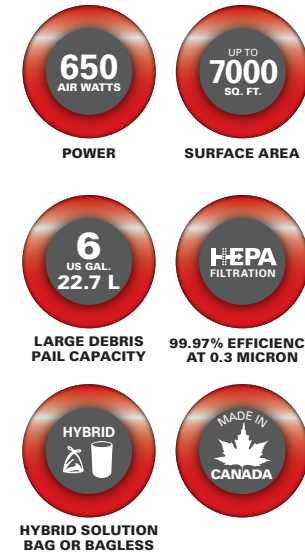

### STANDARD TOOL SET Central vacuum kit includes



- 650 air watt power unit
- 35 ft. garage hose with hanger
- 30 ft. low-voltage hose with hanger
- Telescopic stainless steel wand
- Convenient multisurface brush
- Standard floor brush
- Upholstery, dusting and crevice tools
- Tool storage bag
- One disposable bag, model 391C

## HHKIT550E Powerful and Compact Electric Kit

IDEAL FOR HARD FLOORS  
AND CARPETS WITH  
MEDIUM TO HIGH PILE

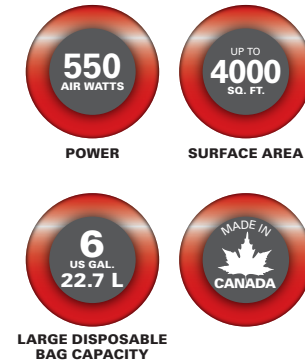

### ELECTRIC TOOL SET Central vacuum kit includes



- 550 air watt power unit
- 35 ft. garage hose with hanger
- 30 ft. dual-voltage hose with hanger
- Telescopic stainless steel wand
- Electric power brush with telescopic wand
- Convenient multisurface brush
- Standard floor brush
- Upholstery, dusting and crevice tools
- Tool storage bag
- One disposable bag, model 391C

## HHKIT550A Powerful and Compact Air Kit

SUITABLE FOR HARD FLOORS  
AND CARPETS WITH LOW PILE

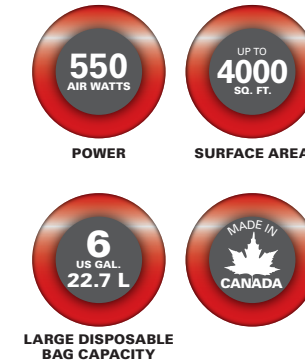

### STANDARD TOOL SET Central vacuum kit includes



- 550 air watt power unit
- 35 ft. garage hose with hanger
- 30 ft. low-voltage hose with hanger
- Telescopic stainless steel wand
- Convenient multisurface brush
- Standard floor brush
- Upholstery, dusting and crevice tools
- Tool storage bag
- One disposable bag, model 391C

## Easy to install

Perfect for new or replacement installations

A multi-direction vacuum inlet makes installation easy even in small spaces. Each model includes a wall mount support for safe and simple installation. Our five-step installation guide facilitates the work and the quality of execution.

See the complete installation guide on [www.nutone.ca](http://www.nutone.ca)



Products may not be exactly as shown.