

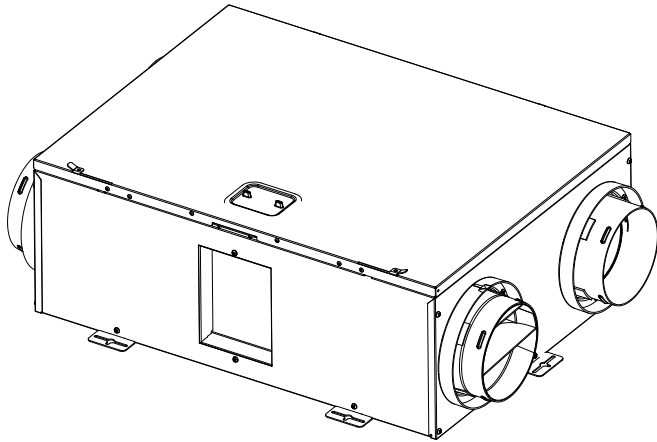

Fresh Air Systems - 150 CFM

Part no. BLP150E75NS-HW (Hardwired)

For plug connected applications, refer to BLP150E75NS-PC



35 to 146 CFM @ 0.4 in. w.g.



Parts/Motor/ERV Core

Visit Broan-NuTone.com for complete warranty text.

The industry's most versatile and advanced fresh air system, created to simplify the design, specification and installation process while delivering superior air quality in a compact design.

- Quickest installation in its category saving the installer up to 20 minutes per unit, thanks to the auto-balancing and self-adjusting VIRTUO™ technology*
- Airflow direction can be swapped with the flip of an integrated selection switch**, eliminating the need for specifying different models to accommodate mirrored floor plans and providing simplicity throughout the design and installation processes
- Horizontal and wall mount options provide location flexibility to accommodate various application needs
- Integrated LCD screen provides intuitive CFM selection in 1 CFM increments throughout the airflow range providing real-time CFM and watt usage values
- Equipped with PMSM ECM motors for reliable and energy efficient operation
- Fault indicator display (FID) responding to filter maintenance, airflow, watt usage and system sensors

*US Patent No. 11168916 - Canadian patent pending

**Patent pending

Optional Controls



There are 4 optional main controls and 2 optional auxiliary controls available. Refer to Wall Control specification sheet for more information.

***Speed selector control available only in the US.

Unit Attributes

- SRE of 84% at 32°F (0°C) (36 CFM)
- Ports size: 6"
- 2.1 CFM/Watt (64 CFM)
- Defrost operation will automatically activate to manage recovery core frost and maintain unit performance. When outdoor air temperature is < 14°F (-10°C), an external pre-heater must be used.
- Corrosion resistant galvanized steel door and cabinet
- One-piece molded insulation shell, no air leakage (expanded polystyrene; UL 94 HF-1 certified)
- VIRTUO™ constant airflow and auto-balancing device
- Integrated motorized dampers (no additional backdraft dampers required)
- No condensate drain required
- Unit electrical characteristics:
Volt: 120/1 60 Hz, MCA: 2.4 A, MCOP: 15 A, Watts: 170

Recovery Core

- ERV polypropylene crossflow core and plastic covers, impact resistant, non washable
- Dimensions: 12" x 24" x 8.5" (30.5 cm x 61 cm x 21.6 cm)

Filtration

- MERV 8 grade washable standard filter (included)
- Optional 2" thick MERV13 grade filter (disposable)

Exterior Termination Options

- Compatible with Tandem Terminations (part no. VTYIK1 and V14695) (CFM output must meet application requirements)

Dimensions

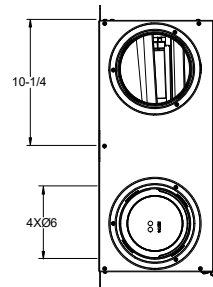
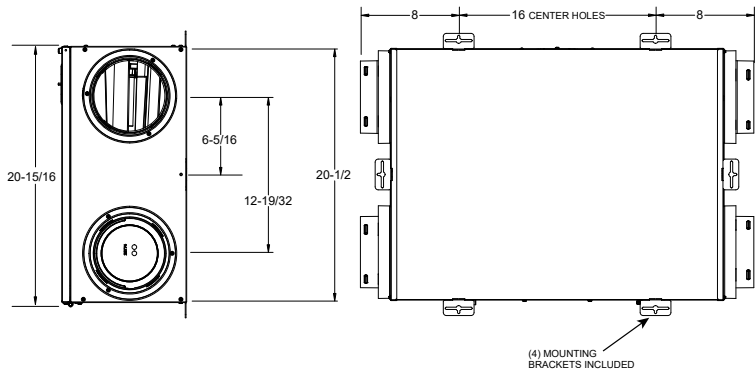
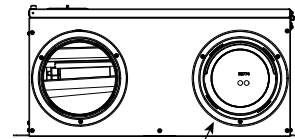
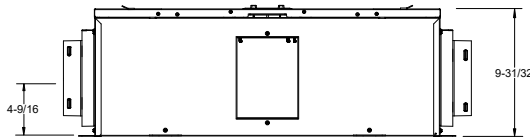
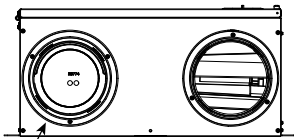
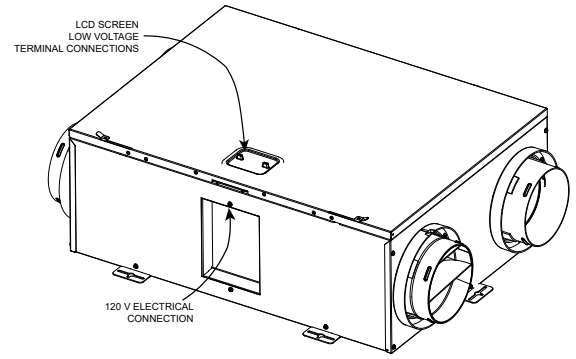
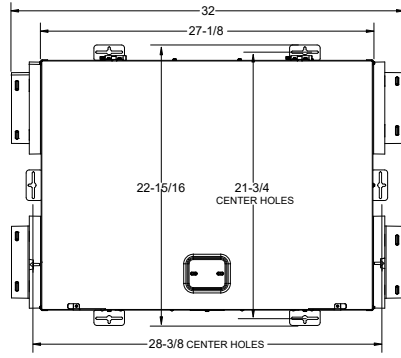

9" CLEARANCE REQUIRED FROM DOOR SURFACE FOR
MAINTENANCE
DOOR FULLY REMOVABLE AFTER 10° OF ROTATION

Fan Curves with VIRTUO™

Thanks to VIRTUO™ technology, no need to balance the unit manually. Both PMSM ECM motors are controlled by an artificial intelligence performing 120 readings per minute then processing this information to maintain the requested airflow.

For typical installation, VIRTUO™ will ensure a balanced ventilation at every selected speed regardless of the weather conditions, the type of connection, the variable speed furnace/AHU, the stack effect, the filter clogging and so on. This results in peace of mind for installers and users knowing that the unit will always remain balanced and that it will maintain its maximum heat/energy recovery efficiency.

STATIC PRESSURE (PA)	STATIC PRESSURE (IN. W.G.)	NET SUPPLY AIRFLOW (L/S)	NET SUPPLY AIRFLOW (CFM)	GROSS AIRFLOW SUPPLY (L/S)	GROSS AIRFLOW SUPPLY (CFM)	GROSS AIRFLOW EXHAUST (L/S)	GROSS AIRFLOW EXHAUST (CFM)
25	0.1	75	159	76	161	76	161
50	0.2	73	155	74	157	74	157
75	0.3	71	150	72	153	72	153
100	0.4	69	146	70	148	70	148
125	0.5	67	142	68	144	68	144
150	0.6	65	138	66	140	66	140
175	0.7	63	133	64	136	64	136
200	0.8	61	129	62	131	62	131
225	0.9	58	123	59	125	59	125
250	1.0	56	119	57	121	57	121

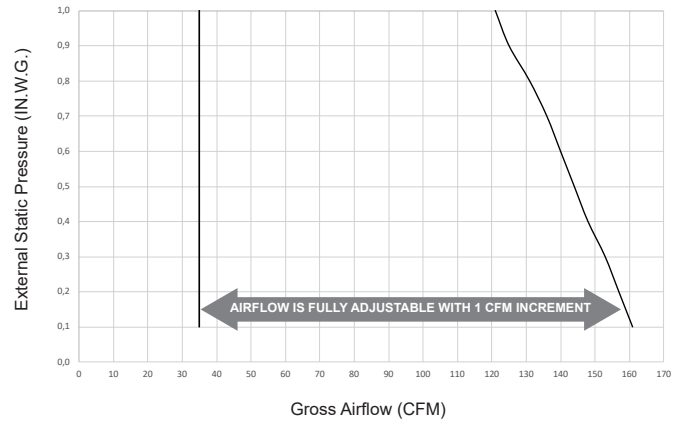

Energy Performance

SUPPLY TEMPERATURE		NET AIRFLOW		POWER CONSUMED WATTS	SENSIBLE RECOVERY EFFICIENCY	ADJUSTED SENSIBLE RECOVERY EFFICIENCY	APPARENT SENSIBLE EFFECTIVENESS*	TOTAL RECOVERY EFFICIENCY	ADJUSTED TOTAL RECOVERY EFFICIENCY	LATENT RECOVERY / MOISTURE TRANSFER
°C	°F	L/S	CFM							
HEATING										
0	32	17	36	17	84%	87%	88%	-	-	0.72
0	32	30	64	31	78%	81%	82%	-	-	0.65
0	32	52	110	70	70%	73%	74%	-	-	0.57
COOLING										
35	95	17	36	20	-	-	82%	72%	75%	0.71
35	95	30	64	32	-	-	74%	65%	68%	0.63
35	95	52	110	75	-	-	65%	55%	58%	0.55

*Data not certified by HVI.

Fan Efficacy

The following data are not certified by HVI but come from measurement in accordance with CSA C439-18.

AIRFLOW (CFM) ¹	AIRFLOW (L/s) ¹	POWER (WATTS)	FAN EFFICACY (CFM/W) ²	FAN EFFICACY (L/s/W) ²
35	17	16.5	2.1	1.00
40	19	18.6	2.1	1.01
45	21	20.8	2.1	1.02
50	24	23.0	2.1	1.03
55	26	25.3	2.1	1.03
60	28	27.7	2.1	1.02
65	31	30.2	2.1	1.02
70	33	32.9	2.1	1.00
75	35	35.8	2.1	0.99
80	38	39.0	2.0	0.97
85	40	42.4	2.0	0.95
90	42	46.1	1.9	0.92
95	45	50.1	1.9	0.90
100	47	54.4	1.8	0.87
105	50	59.1	1.8	0.84
110	52	64.2	1.7	0.81
115	54	69.8	1.7	0.78
120	57	75.8	1.6	0.75
125	59	82.3	1.5	0.72
130	61	89.3	1.5	0.69
135	64	96.9	1.4	0.66
140	66	105.0	1.3	0.63
145	68	113.7	1.3	0.60
150	71	123.1	1.2	0.58
155	73	133.1	1.2	0.55

¹ Gross airflow measured at 70°F/21°C sea level, supply and exhaust stream balanced and equivalent external differential pressure of 0.2" w.g. 50 Pa applied to each stream.

² Fan efficacy calculated from balanced gross airflow divided by measured power then rounded to one decimal for I-P units (CFM/W) or 2 decimals for SI units (L/s/W).

Requirements and Standards

- UL 1812 compliant (safety)
- Performance tested in accordance with CSA C439 Standard
- Compliant with Prop 65
- Can be used to comply with ASHRAE standard 62.2
- Can be used to comply with ASHRAE 90.1-2019 requirements
- Can be used to comply with International Energy Conservation Code (IECC) requirements
- Can be used to comply with California Title 24 2019 Part 6 Fault Indicator Display Requirements
- Can be used to earn WA energy code credits
- HVI certified

Project:	Remarks
Location:	
Part no.:	
Qty.:	
Submitted by: Date:	