

Antero's surfaces flow together in a stunning and sophisticated look that anyone would be proud to have in their kitchen. Modern features such as the quiet Captur™ system, LED lighting and tap-touch controls make it a pleasure to use. The LED modules included with this hood are the latest in LED cooktop illumination technology specially designed to operate in the elevated temperatures of cooking - offering bright lighting and lasting up to 25 times as long as a standard bulb and greater reliability than typical replacement LED bulbs.

SIZE	STAINLESS	GREASE FILTERS (replacement)	NON-DUCTED FILTERS
30 in.	CLDH130SS	HPFA3A30 (Type C3)	HPF30 (Type Xc)

FEATURES	
Max. Blower CFM†	450
Control type	3-speed Capacitive Touch
Delay off	no
Filter Clean Reminder	yes
Heat Sentry™	no
ADA Capable	yes
Lighting	2-level LED (included)
Grease Filters	Deluxe Micro Mesh (Qty. 2)
Installation Hardware	EZ1 brackets
ENERGY STAR®	no
Recirculation	Non-ducted filters sold separately
AC INPUT	
120 V, 60 Hz - 1.4 AMPS	
OPTIONAL ACCESSORIES	
7-in. Round Damper	BP87Q
ADA Wiring Kit	HAWRK3
Make-up Air Dampers	MD6TU, MD8TU and MD10TU
MOUNTING HEIGHT	
18 in. to 30 in. from cooktop to bottom of hood	
LIMITED WARRANTY	
1-year	
3-year (LED bulbs only)	
<i>See instruction manual for full warranty text.</i>	
FOR INDOOR USE ONLY	

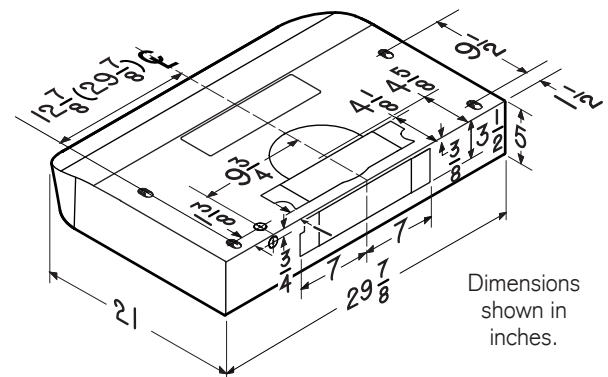

Dimensions shown in inches.

† Max. blower CFM indicates the performance of the hood blower in open air and is not HVI certified.



HVI PERFORMANCE									
Duct Orientation	Size	Damper	Sones			CFM			
			Normal	Medium*	High	Normal	Medium*	High 0.25 in. w.g.	High 0.1 in. w.g.
Vertical - Rectangular	3¼ x 10 in.	Included	0.4	2.5	6.0	140	230	310	360
Horizontal - Rectangular	3¼ x 10 in.	Included	0.4	2.0	5.5	150	240	340	400
Round - Vertical	7 in.	Sold Separately	0.4	2.0	5.5	150	220	320	380

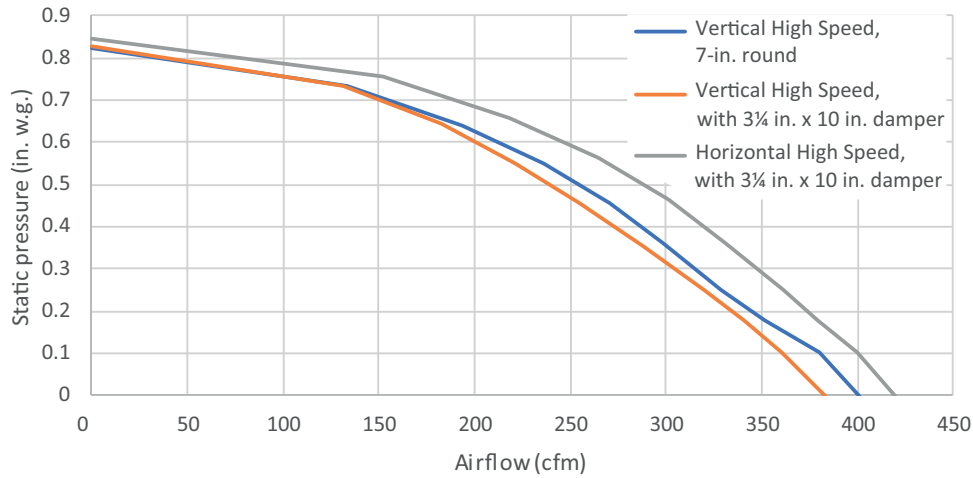

HVI-2100 CERTIFIED RATINGS comply with new testing technologies and procedures prescribed by the Home Ventilating Institute, for off-the-shelf products, as they are available to consumers. Product performance is rated at 0.1 and 0.25 in. static pressure at high speed based on tests conducted in an HVI-approved state-of-the-art test laboratory. Sones are a measure of humanly-perceived loudness, based on laboratory measurements.

* Where noted performance rating is not HVI certified but was established in accordance with HVI Standardized test procedure.